



Parts Manual

Mfg. No: 5901736
FW15 Series w/ 32" Mower Deck
(FW15HON1032)



5601157 - Mulch Kit for W15 Walk Behind w/ 32" Deck.
5601159 - Kit, W15 Grass Collection System.
5601233 - Oil Drain Kit.

Not For
In Reproduction

Model Components	Page
Cut Height Adjustment Group.....	4
Decal Group - Brand and Model.....	6
Decal Group - Safety and Operation.....	8
Engine Group.....	10
Frame, Spindles, and Blades Group.....	12
Handle Bar Group.....	14
Hydraulic Drive Group.....	16
Motion Control Group - Lower.....	18
Motion Control Group - Upper.....	20
Pulleys, Belt, and Idler Arm Group.....	22
Rear Drive Group.....	24
Spindle Service Parts - 5417770.....	26
Transaxle SERVICE Parts - Hydro-Gear RT-310 (5105873).....	28
Wheel and Tire Group.....	30
Torque Specification Chart.....	32

Not For
In Reproduction

Cut Height Adjustment Group

Note: Unless noted otherwise, use the standard torque specifications

Mfg. No: 5901736

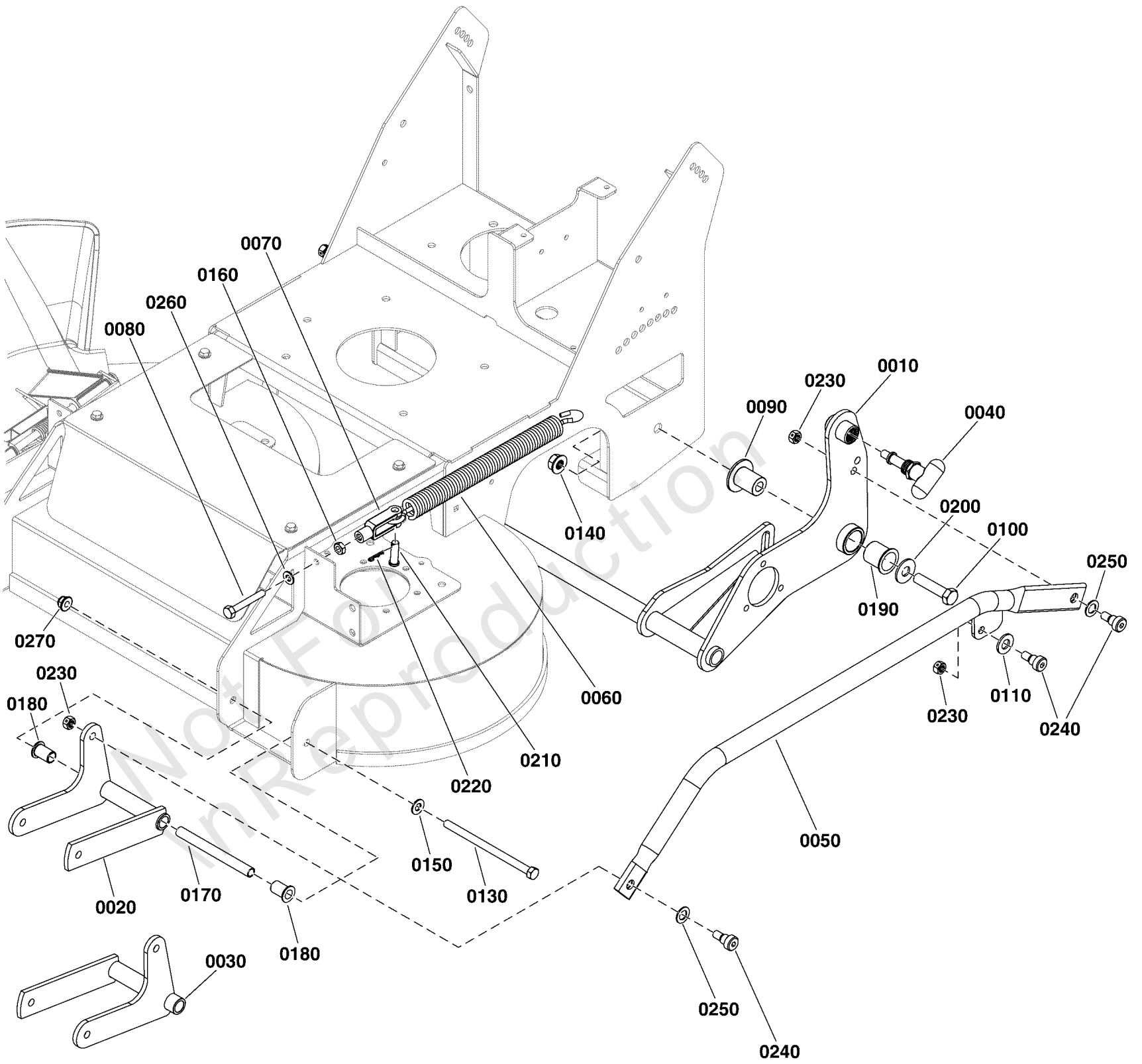

Cut Height Adjustment Group

REF NO	PART NO	QTY	DESCRIPTION
0010	5417551B	1	WELD, REAR DIFF MOUNT, 32W - RED
0020	5417553B	1	WELD, LH FRONT WHEEL MOUNT - RED
0030	5417552B	1	WELD, RH FRONT WHEEL MOUNT - RED
0040	5104609	1	PULL PIN, 3/8" DIA X 9/16" STROKE
0050	5417776AA	2	WELD, DECK HEIGHT TUBE, FW15 - BLK
0060	5023355	2	SPRING-EXT, 1.00 ODX13.25LGX.177WR, BLK
0070	5100375	2	CLEVIS, 5/16-18, 3/8 PIN HOLE, CLR ZINC
0080	5025055X18	2	BOLT, 5/16-18 X 2-1/4 TFL, GD5 YZ
0090	5106380	2	SPACER, SHOULDER, WALK
0100	5025017X18	2	BOLT, 1/2-13 X 2-1/4" GD5 CZ
0110	5025158	2	WASHER, 1/2 SAE
0130	5025013X48	2	BOLT, 3/8-16 X 6" GD5 CZ
0140	5025396	2	NUT, Hex Flange, Nylock, 1/2-13
0150	5025156	2	WASHER, 3/8 SAE
0160	5025388	2	NUT, 5/16-18 HEX JAM
0170	5046586	2	SPACER, .38 X .50 X 5.06, CZ
0180	5107528	4	BUSHING, FLG, .5 ID X 5/8 OD X 1 LG
0190	5023343	2	BUSHING, 1.00 X 1.13 X 1.38, Plastic
0200	5025150	2	WASHER, 1/2" USSZ
0210	5025214X8	2	PIN-CLEVIS, 3/8 X 1 YZ
0220	5025211	2	PIN, HAIR, .0585 X 1-1/8, 1/4 EYE, YZ
0230	5025100	6	NUT, Hex, Side Lock, 3/8-16
0240	5025356	6	BOLT, 3/8-16 X 3/8", 1/2" SHOULDER
0250	80003590	4	WASHER, .516IDX.875ODX.06,FLAT,ZC/CL
0260	5025155	2	WASHER, 5/16" SAE
0270	5025394	2	NUT, 3/8 - 16 HEX NYLOCK FLANGE

Decal Group - Brand and Model

Note: Unless noted otherwise, use the standard torque specifications

Mfg. No: 5901736

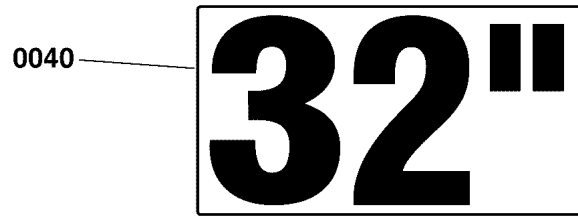
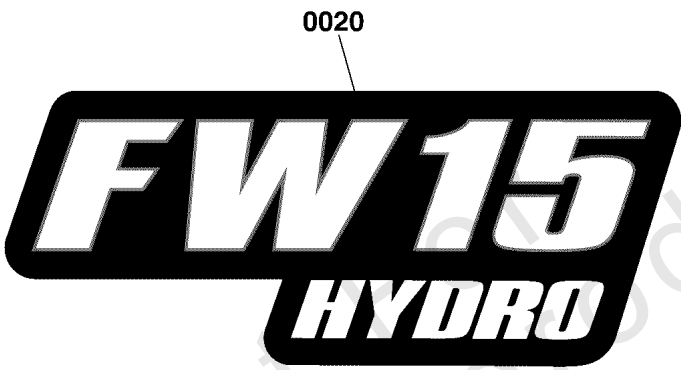
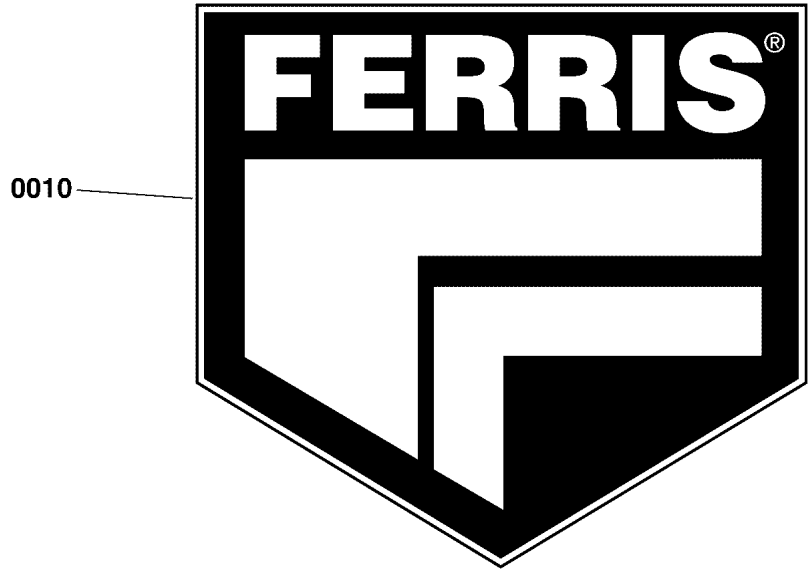
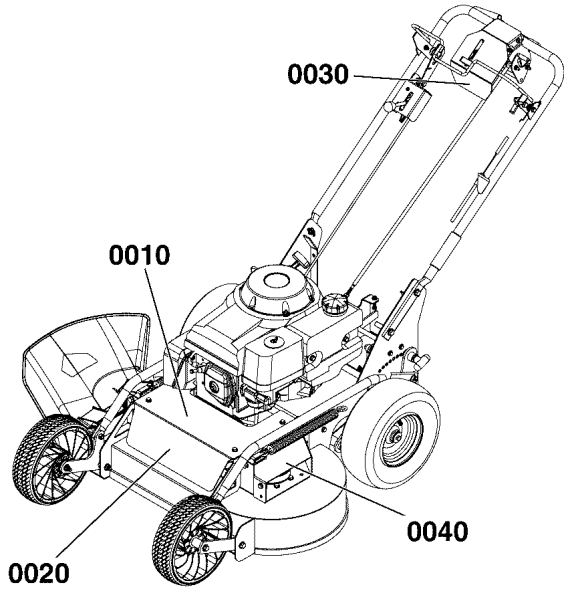

Decal Group - Brand and Model

REF NO	PART NO	QTY	DESCRIPTION
0010	5104756	1	DECAL, FERRIS LOGO, SMALL
0020	5107425	1	DECAL, MODEL, FW15 HYDRO
0030	5107428	1	DECAL, FERRIS TEXT, 5"
0040	5102953	1	DECAL, 32

Not For In Reproduction

Decal Group - Safety and Operation

Note: Unless noted otherwise, use the standard torque specifications

Mfg. No: 5901736

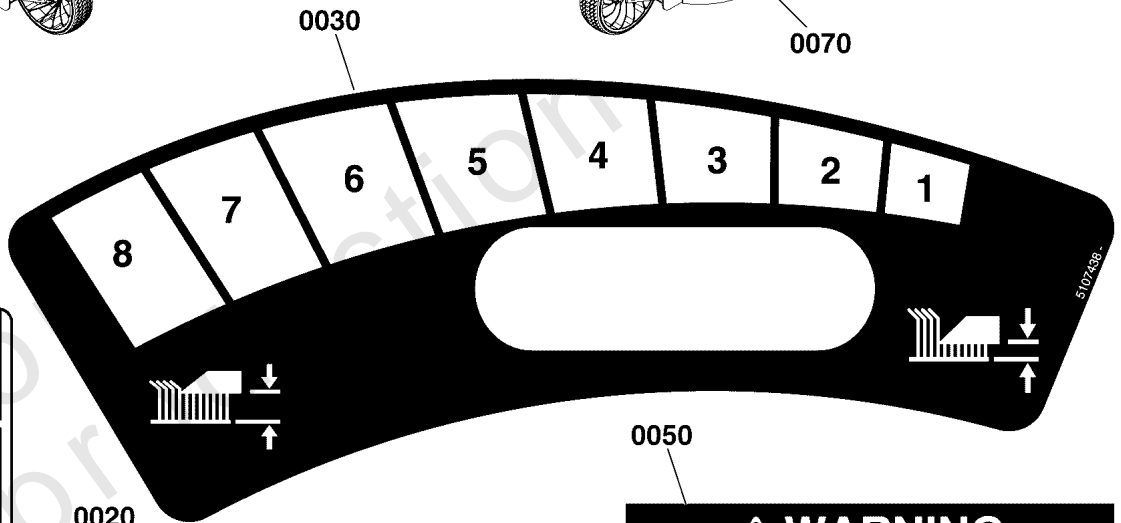
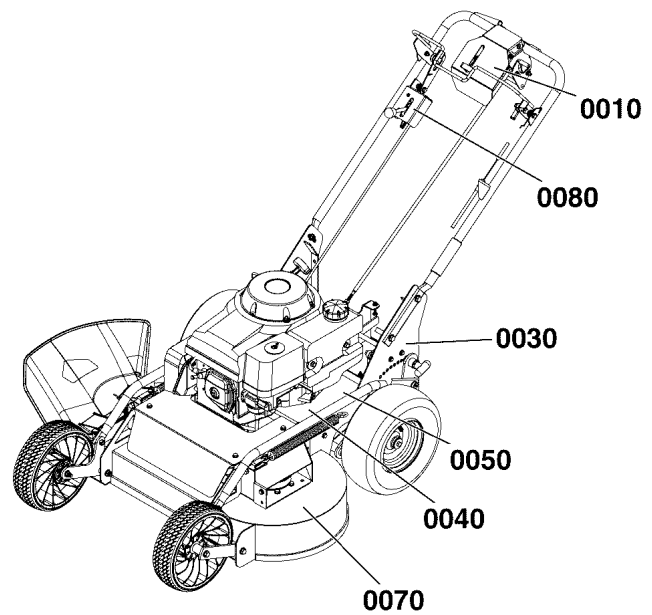
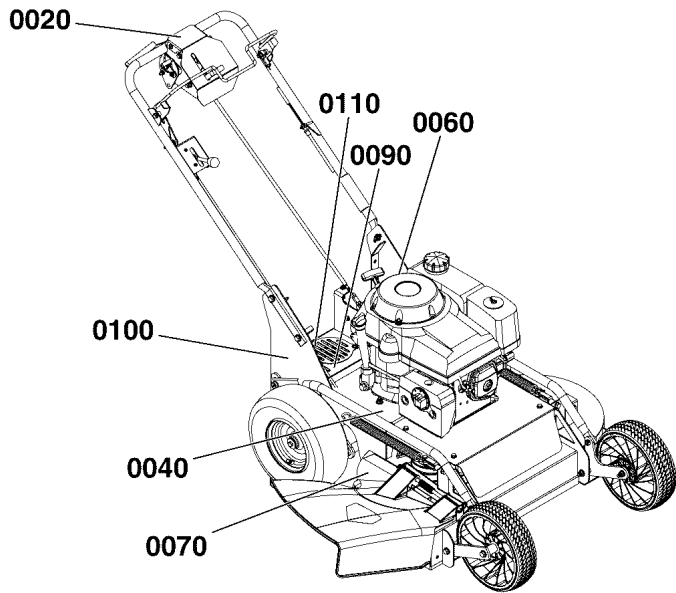

WARNING

Avoid serious injury or death

- Read operator's manual before using this product.
- Go across slopes, NOT up and down.
- Look down and behind before and while backing.
- Stop the mower when children or others are near.
- Remove objects that could be thrown by the blade.
- Keep safety devices (guards, shields, switches, etc.) in place and working.
- Do NOT operate this machine unless you are trained.
- Know the location and function of all controls.
- Avoid steep slopes. Reduce speed and use extreme caution on slopes.

5107426 -

0020

5107427 -

WARNING

Fire Hazard

Gasoline is flammable. Debris is combustible.

- Allow engine to cool for at least 3 minutes before refueling.
- Keep unit cleaned of debris
- This equipment may create sparks that can start fires around dry vegetation. A spark arrester may be required. Contact local fire agencies for regulations relating to fire prevention requirements.

5103665

WARNING

PINCH POINT

To avoid injury from loaded spring, read operator's manual before removing spring.

61245

DANGER

Amputation and thrown objects hazard

- Keep hands and feet away from deck.
- Do not operate mower unless discharge chute or entire grass catcher is in its proper place.

5107606 -

0060

5107608 -

0080

5107758 -

0090

0100

The operator's manual is available in Spanish. La manual del operador está disponible en Español.

5104269 A

System complies with Canadian standard ICES-002.

0110

WARNING

Cancer and Reproductive Harm

www.P65Warnings.ca.gov

Decal Group - Safety and Operation

REF NO	PART NO	QTY	DESCRIPTION
0010	5107426	1	DECAL, MAIN SAFETY, SMALL WALK
0020	5107427	1	DECAL, OPERATIONAL CONTROLS, FW15
0030	5107438	1	DECAL, CUT HEIGHT, FW15
0040	5061245	2	DECAL, Pinch Point
0050	5103665	1	DECAL, FIRE HAZARD, 3.25W X 3.0H
0060	5107605	1	DECAL, CHOKE -(Located on engine by choke lever.)
0070	5107606	2	DECAL, DANGER, DISCHARGE
0080	5107608	1	DECAL, THROTTLE AND ENGINE STOP
0090	5107758	1	DECAL, TRANSAXLE RELEASE, SML WB
0100	5104269	1	DECAL, SPANISH MANUAL, IGES, C-TICK
0110	383202	1	LABEL, WARNING

Not For In Reproduction

Honda Engine Service Parts

0030-10 - Air Cleaner

0030-20 Fuel Cap

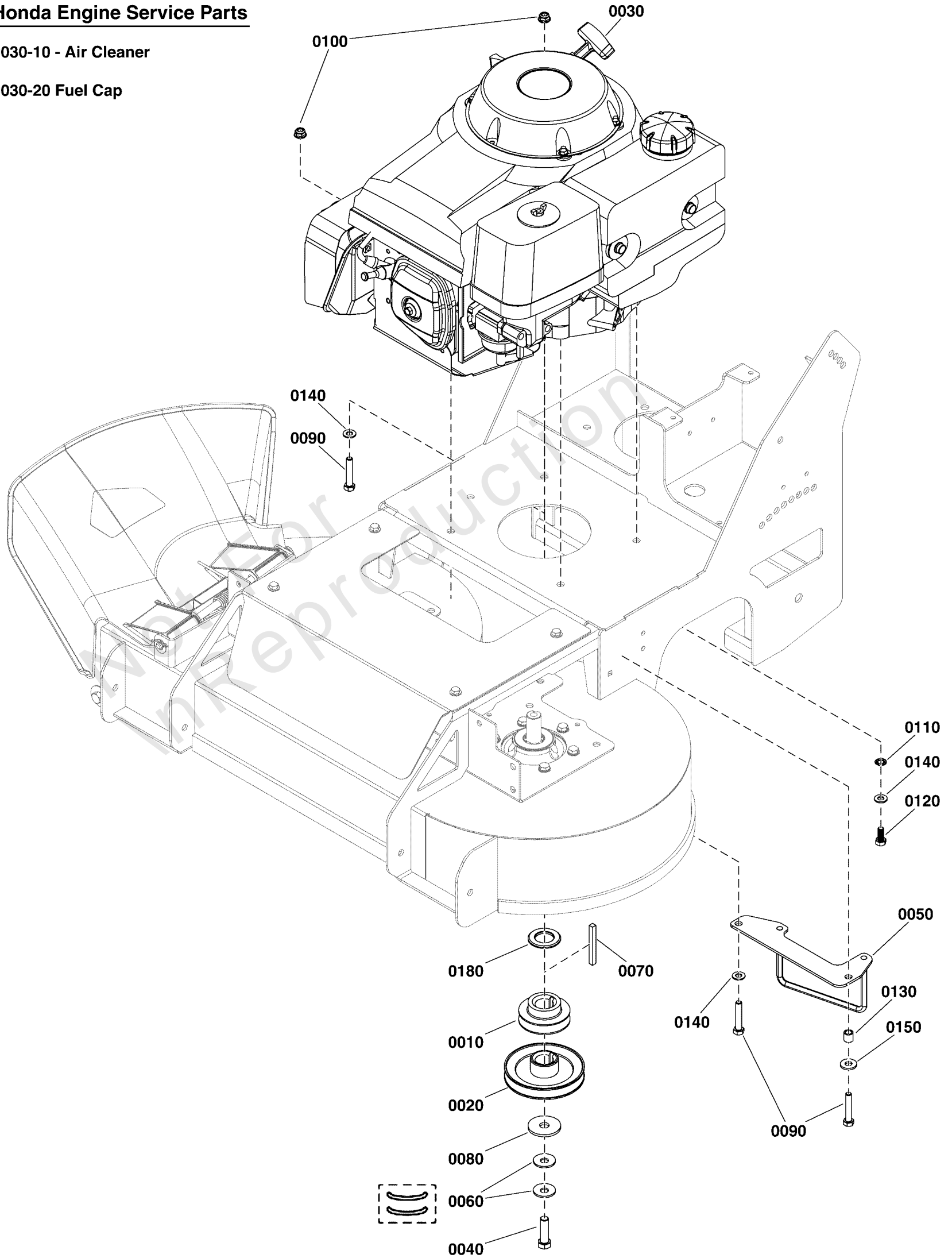

Engine Group

REF NO	PART NO	QTY	DESCRIPTION
0010	5021830	1	PULLEY, Transmission Drive
0020	5023252	1	PULLEY, Crankshaft, 1.0005 ID X 4.275 OD
0030	-----	1	ENGINE, HONDA GXV390, 10.2 HP -(Refer to Note: *)
0030-10	5106388X1	1	AIR CLEANER, HONDA
0030-20	5106388X2	1	FUEL CAP, HONDA
0040	5102860	1	BOLT, CRANKSHAFT, 7/16-20 X 1-1/2, GD8
0050	5417806AA	1	WELD, ENGINE BELT KEEP - BLK
0060	5025585	2	BELLEVILLE WASHER, 1.1875 X .442 X .098
0070	5050407X20	1	Key, 1/4" Sq. x 2-1/2"
0080	5103282	1	WASHER, .52 X 1.75 X 0.14, CZ
0090	5025025X14	3	BOLT, 5/16-24 X 1-3/4, GD8, PHOS
0100	5025616	2	NUT, 5/16-24, TOP LOCK FLANGE, GD8 PHOS
0110	5025188	1	WASHER, 5/16" Internal Tooth Lock
0120	5025012X6	1	BOLT, 5/16-24 x 3/4
0130	5102148	1	SPACER, .33 X .50 X .50, YZ
0140	5025155	3	WASHER, 5/16" SAE
0150	5025337	1	WASHER, 5/16" USS
0180	5107928	1	SPACER, 1.0 X .125 X 1.75, CZ

Footnotes:

Note: *Refer to you local Honda distributor for parts and service.

Frame, Spindles, and Blades Group

Note: Unless noted otherwise, use the standard torque specifications

Mfg. No: 5901736

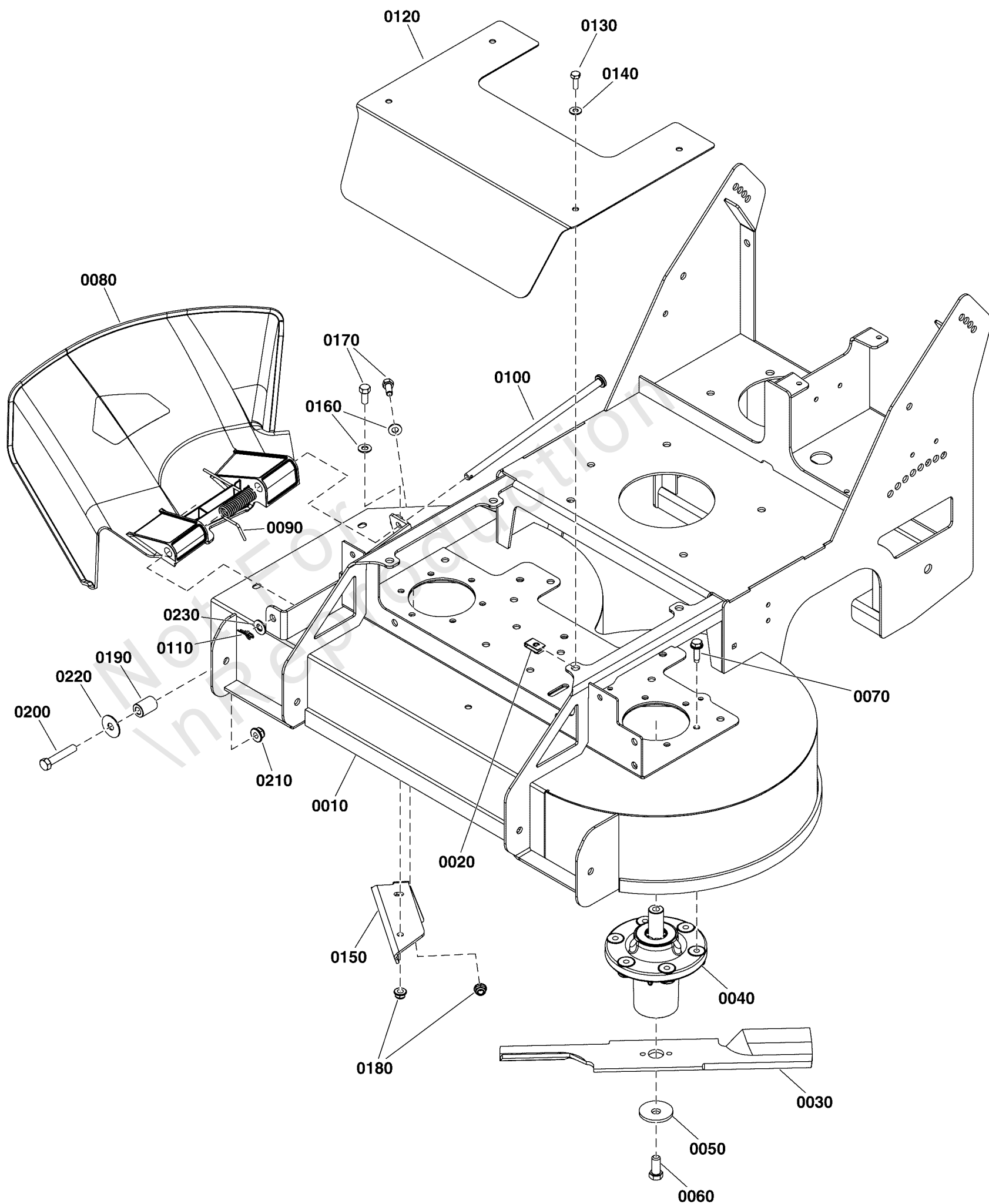

Frame, Spindles, and Blades Group

REF NO	PART NO	QTY	DESCRIPTION
0010	-----	1	FRAME AND DECK WELDMENT, RIGID -(Refer to Note: *)
0020	5022665	4	BODY CLIP, 1/4-20 X 1/2" DEEP
0030	5106420X2	1	BLADE SET, 32 DECK (2) -(SET OF 2 BLADES)
0040	5417770	2	ASSY, ALUM. SPINDLE, 1761445 HOUSING, FW15
0050	1656916	2	WASHER, .475 ID x 1.75 OD x .156 Thick Spring, Black
0060	80020425	2	CAPSCREW-HEX HD 7/16-14X1.000 G5 ZC/CL
0070	80006216	12	SCREW, 5/16-18X1.000, HEX WSHR HD, TT, ZC/CL
0080	5106405	1	CHUTE, DISCHARGE, FW15
0090	5023385	1	SPRING, TORSION
0100	5106448	1	ROD, 3/8 X 9.88, HEADED, CZ
0110	80004458	1	COTTER PIN, 3/8 SELF LOCKING, CLEAR/ZINC
0120	5417773B	1	GUARD, FRONT, FW15 - RED
0130	5025010X6	4	BOLT, 1/4"-20 X 3/4" GD5 YZ
0140	5025154	4	WASHER, 1/4 SAE
0150	5417819AA	1	PLATE, DEFECTOR, FW15 - BLK
0160	5025155	3	WASHER, 5/16" SAE
0170	5025011X6	3	BOLT, 5/16-18 X 3/4 GD5
0180	5025392	3	NUT, 5/16-18 HEX NYLOCK FLANGE NUT
0190	5042658	1	SPACER, .38 X .75 X 1.06, YZ
0200	5025013X16	1	BOLT, 3/8-16 X 2, GD5, CZ
0210	5025394	1	NUT, 3/8 - 16 HEX NYLOCK FLANGE
0220	5025165	1	WASHER, 3/8" Fender
0230	5025156	1	WASHER, 3/8 SAE

Footnotes:

Note: *If frame and deck assembly becomes damaged, contact the Service Department at 1 (800) 933-6175, and select Service option.

Handle Bar Group

Note: Unless noted otherwise, use the standard torque specifications

Mfg. No: 5901736

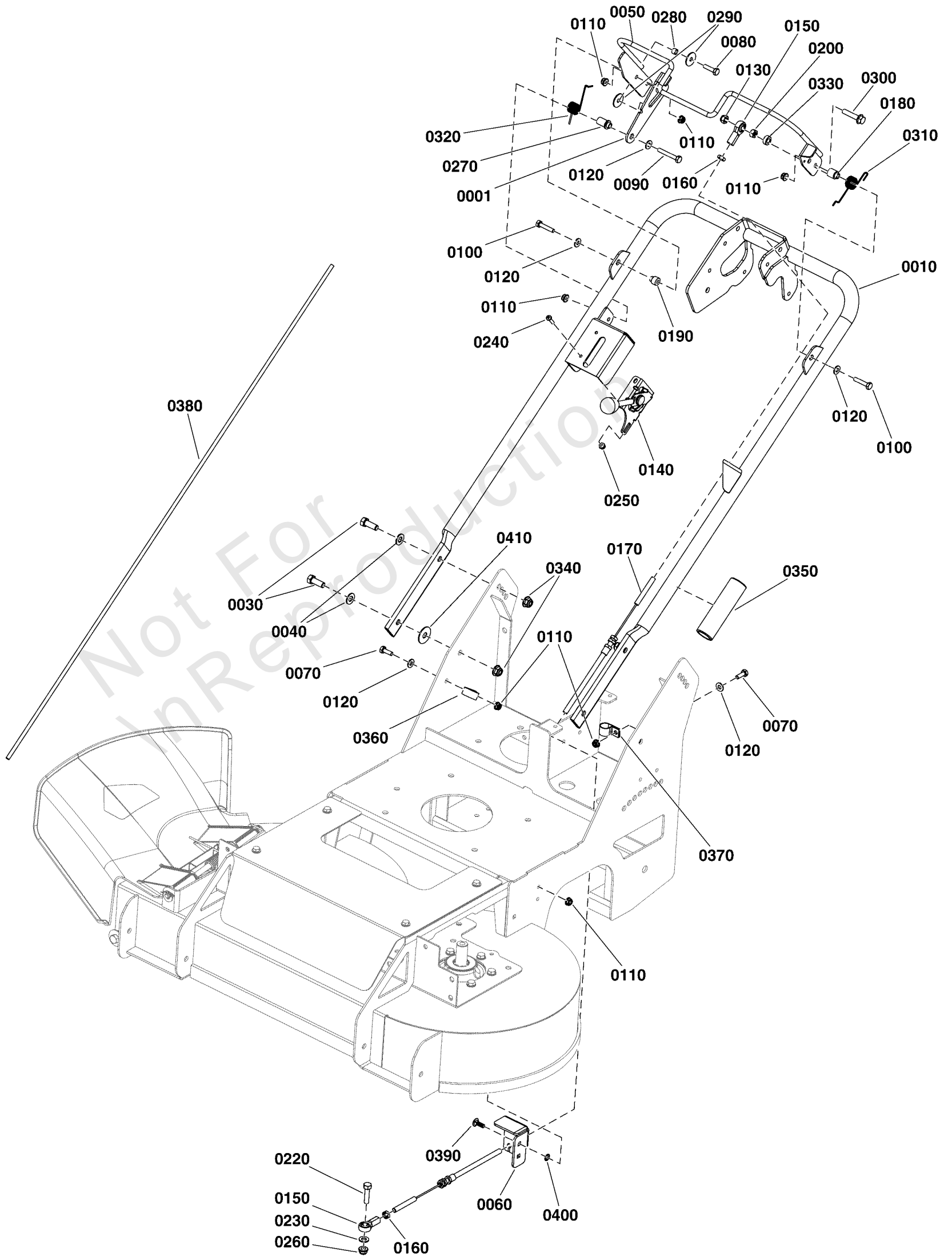

Handle Bar Group

REF NO	PART NO	QTY	DESCRIPTION
0001	5419009B	1	PLATE, OPC LOCK - RED
0010	5419039AA	1	WELD, HANDLE BAR, FW15 - BLK
0030	5025013X8	4	BOLT, 3/8-16 X 1" GD5 CZ
0040	5025156	4	WASHER, 3/8 SAE
0050	5419038AA	1	WELD, OPC CONTROL - BLK
0060	5418839AA	1	PLATE, CABLE MOUNT, LOWER - BLK
0070	5025010X6	2	BOLT, 1/4"-20 X 3/4" GD5 YZ
0080	5025010X8	1	BOLT, 1/4-20 X 1" GD5 CZ
0090	5025010X4	1	BOLT, 1/4-20 x 1/2
0100	5025010X10	2	BOLT, 1/4-20 X 1-1/4 GD5 CZ
0110	5025391	7	NUT, 1/4-20 Hex Nylock Flange
0120	5025154	5	WASHER, 1/4 SAE
0130	5025057	1	NUT, Hex, Nylon Locking, 5/16-18
0140	5107399	1	THROTTLE CONTROL LEVER ASM
0150	5104493	2	BALL JOINT 5/16-24 RH FEMALE BRONZE RACE
0160	5023216	2	NUT, Hex Jam, 5/16-24
0170	5106553	1	CABLE, BLADE ENGAGE, FW15
0180	5107579	1	SPACER, SPRING PIVOT, CZ
0190	5107541	1	SPACER, SHOULDER, .25ID, CZ
0200	5025032	1	NUT, 5/16-18 HEX
0220	5025055X10	1	BOLT, 5/16-18 x 1-1/4" TFL GD 5
0230	5025155	1	WASHER, 5/16" SAE
0240	5025179X6	2	SCREW, #10-24 X 3/4" ROUND PHILLIPS
0250	5025271	2	NUT, Hex, Nylon Lock, #10-24
0260	5025392	1	NUT, 5/16-18 HEX NYLOCK FLANGE NUT
0270	5107578	1	SPACER, LATCH PIVOT, CZ
0280	5102813	1	SPACER, .265 X .375 X .250, CZ
0290	5025288	2	WASHER, 1/4" Fender
0300	5023157	1	BOLT, Flange Head, 5/16-18 x 1-1/2
0310	5107542	1	SPRING, TROSION, 8 IN-LB
0320	5107533	1	SPRING, TORSION, 11 IN LBS
0330	5104654	1	SPACER, .33 X .63 X .25, CZ
0340	5025394	4	NUT, 3/8 - 16 HEX NYLOCK FLANGE
0350	5107718	1	GRIP, FOAM, 1" ID, 4.50 LONG
0360	5021500	1	CLAMP, VINYL INSULATED, 1.00
0370	5101932	1	CLAMP, VINYL INSULATED, .625
0380	5101073	1	CABLE, Throttle Control, 42"
0390	80003518	2	BOLT,1/4-20X0.750,GR5,STD NECK,SQ,ZC/CL
0400	80004801	2	BOLT,1/4,PUSHNUT RETAINER,PHOSPHATE/OIL
0410	5025165	2	WASHER, 3/8" Fender

Hydraulic Drive Group

Note: Unless noted otherwise, use the standard torque specifications

Mfg. No: 5901736

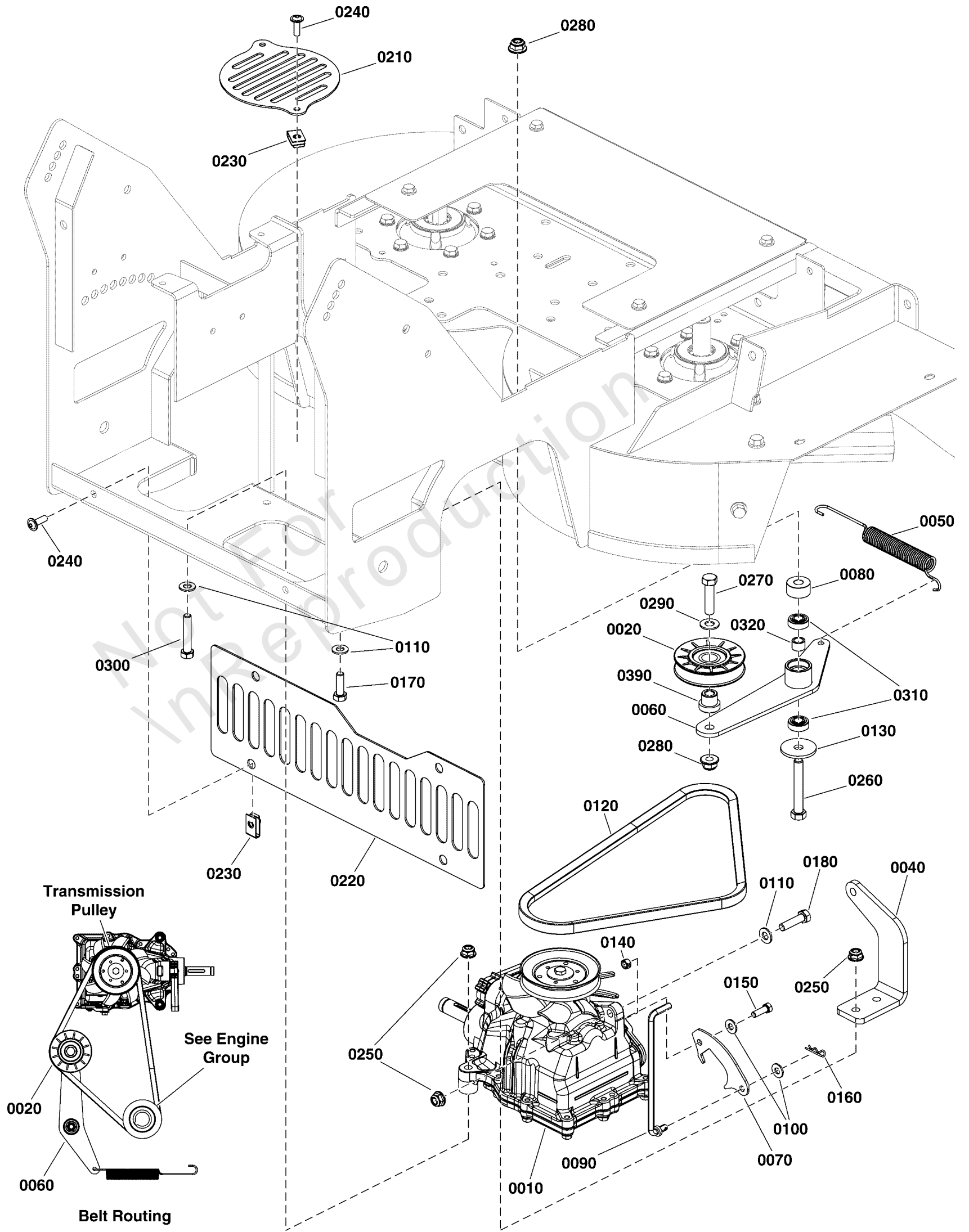

Hydraulic Drive Group

REF NO	PART NO	QTY	DESCRIPTION
0010	5105873	1	TRANSMISSION, RT-310
0020	5021079	1	Idler Pulley
0040	5417525AA	1	BRACKET, TRANSMISSION MOUNT - BLK
0050	1758045	1	SPRING, EXTENSION
0060	5417807AA	1	WELD, HYDRO IDLER - BLK
0070	5418882AA	1	PLATE, HYDRO RELEASE ARM - BLK
0080	5046860	1	SPACER, .39 X 1.00 X .50, PM, CZ
0090	5107506	1	ROD, NEUTRAL LOCK, FW15
0100	5025154	2	WASHER, 1/4 SAE
0110	5025155	5	WASHER, 5/16" SAE
0120	5106382	1	BELT, A-SEC, 32.1" EL, ARAMID WRAP
0130	5100548	1	WASHER, .390 X 1.50 X .109, YZ
0140	5025287	1	NUT, Hex, Side Locking, 1/4-20
0150	-----	1	HHCS, 1/4-20 X 0.625, GR5, ZINC/CLEAR
0160	5025211	1	PIN, HAIR, .0585 X 1-1/8, 1/4 EYE, YZ
0170	5025011X8	2	BOLT, 5/16-18 X 1" GRD5 YZ
0180	5025055X10	1	BOLT, 5/16-18 x 1-1/4" TFL GD 5
0210	5417682AA	1	PLATE, GUARD, HYDRO PULLEY - BLK
0220	5419037B	1	PLATE, REAR GUARD, HW10 - RED
0230	5022665	6	BODY CLIP, 1/4-20 X 1/2" DEEP
0240	5106757	6	SCREW, FLANGE, ALLEN HD, 1/4-20 X .75 SS
0250	5025392	5	NUT, 5/16-18 HEX NYLOCK FLANGE NUT
0260	5025013X20	1	BOLT, 3/8-16 X 2-1/2" GD5 CZ
0270	5025013X12	1	BOLT, 3/8-16 X 1-1/2" GD5 CZ
0280	5025394	2	NUT, 3/8 - 16 HEX NYLOCK FLANGE
0290	5025156	1	WASHER, 3/8 SAE
0300	5025011X14	2	BOLT, 5/16-18 X 1-3/4" GD5 YZ
0310	5102003	2	BEARING, .375" ID X .875" OD X .341" THK
0320	5103676	1	SPACER, .39 X .55 X .38, PM, CZ
0390	5021879	1	INSERT, Bearing, Shoulder

Motion Control Group - Lower

Note: Unless noted otherwise, use the standard torque specifications

Mfg. No: 5901736

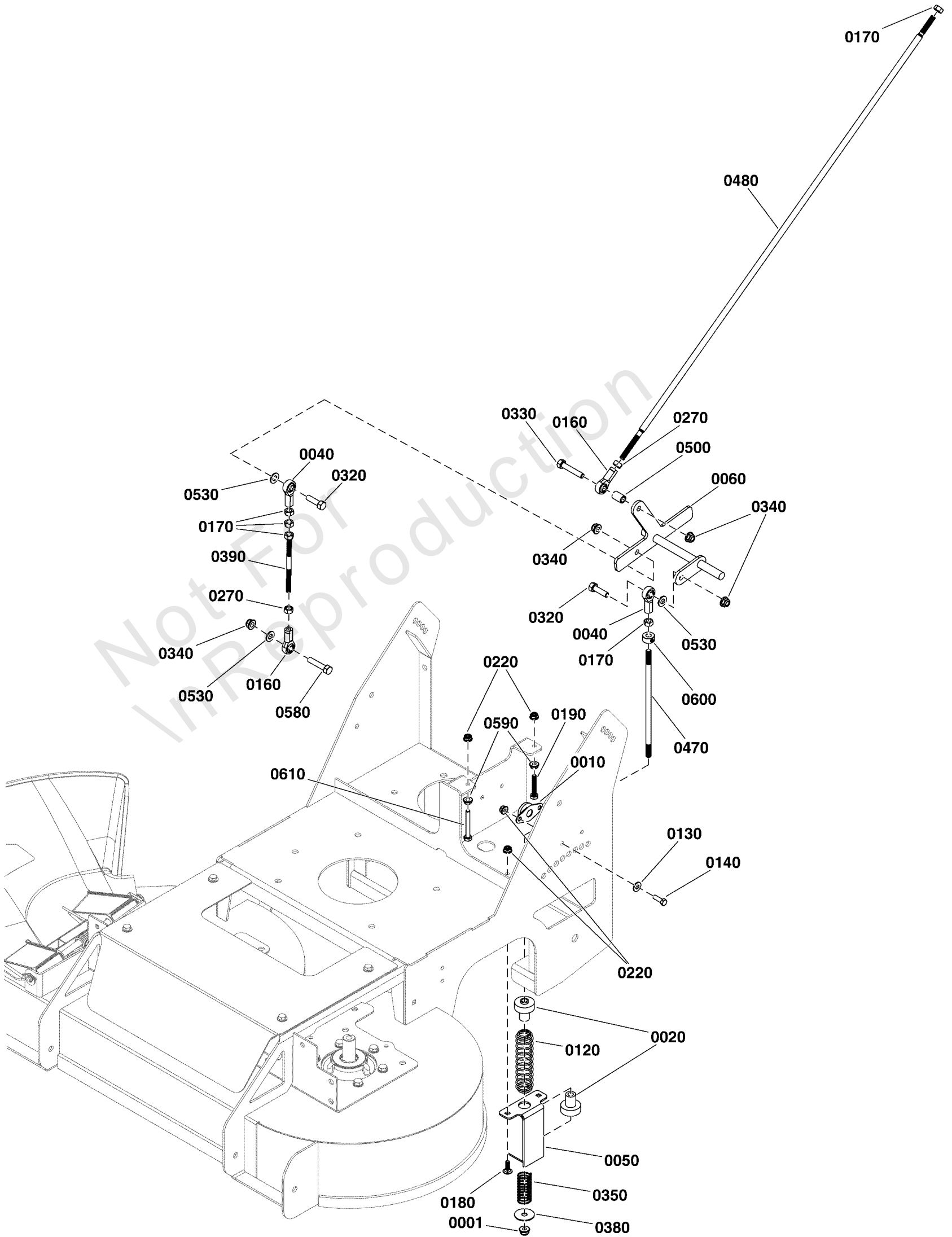

Motion Control Group - Lower

REF NO	PART NO	QTY	DESCRIPTION
0001	5025045	1	NUT, Hex, Nylon Lock, 5/16-24
0010	5101123	2	BEARING, 1/2 FLANGED, PLASTIC BALL
0020	5042911	2	GUIDE, Spring Return
0040	5104493	2	BALL JOINT 5/16-24 RH FEMALE BRONZE RACE
0050	5417738AA	1	WELD, NEUTRAL RETURN BOX - BLK
0060	5418745AA	1	WELD, MOTION CONTROL LOWER - BLK
0120	5107543	1	SPRING, FORWARD RETURN, FW15
0130	5025154	5	WASHER, 1/4 SAE
0140	-----	4	HHCS, 1/4-20 X 0.625, GR5, ZINC/CLEAR
0160	5104494	2	BALL JOINT 5/16-24 LH FEMALE BRONZE RACE
0170	5025033	5	NUT, Hex, 5/16-24
0180	80003518	2	BOLT, 1/4-20X0.750,GR5,STD NECK,SQ,ZC/CL
0190	5025010X12	1	BOLT, 1/4-20 X 1-1/2 GD5 CZ
0220	5025391	8	NUT, 1/4-20 Hex Nylock Flange
0270	5023212	2	NUT, 5/16-24 HEX, LH
0320	5025011X9	2	BOLT, 5/16-18 X 1-1/8 GD5 CZ
0330	5025011X14	1	BOLT, 5/16-18 X 1-3/4" GD5 YZ
0340	5025392	3	NUT, 5/16-18 HEX NYLOCK FLANGE NUT
0350	1709660	1	SPRING-COMP 0.880ODX 02.187LG .062WIRE
0380	5025164	1	WASHER, 5/16" Fender
0390	5104608	1	ROD, 5/16-24 X 4.25, CZ
0470	5107716	1	ROD, NEUTRAL RETURN, FW15
0480	5107534	1	ROD, MOTION CONTROL, FW15 -(Connects to item #0040 in Motion Control Group - Upper
0500	5101352	1	SPACER, .33 X .50 X .75
0530	5025155	2	WASHER, 5/16" SAE
0580	5025011X12	1	BOLT, 5/16-18 X 1-1/2" GD5 YZ
0590	5025126	3	NUT, Hex, Serrated Flange, 1/4-20
0600	5020047	1	COLLAR, 5/16" Set
0610	5025664	1	BOLT, HEX, 1/4-20 X 2" TFL, GRADE 5, CZ

Motion Control Group - Upper

Note: Unless noted otherwise, use the standard torque specifications

Mfg. No: 5901736

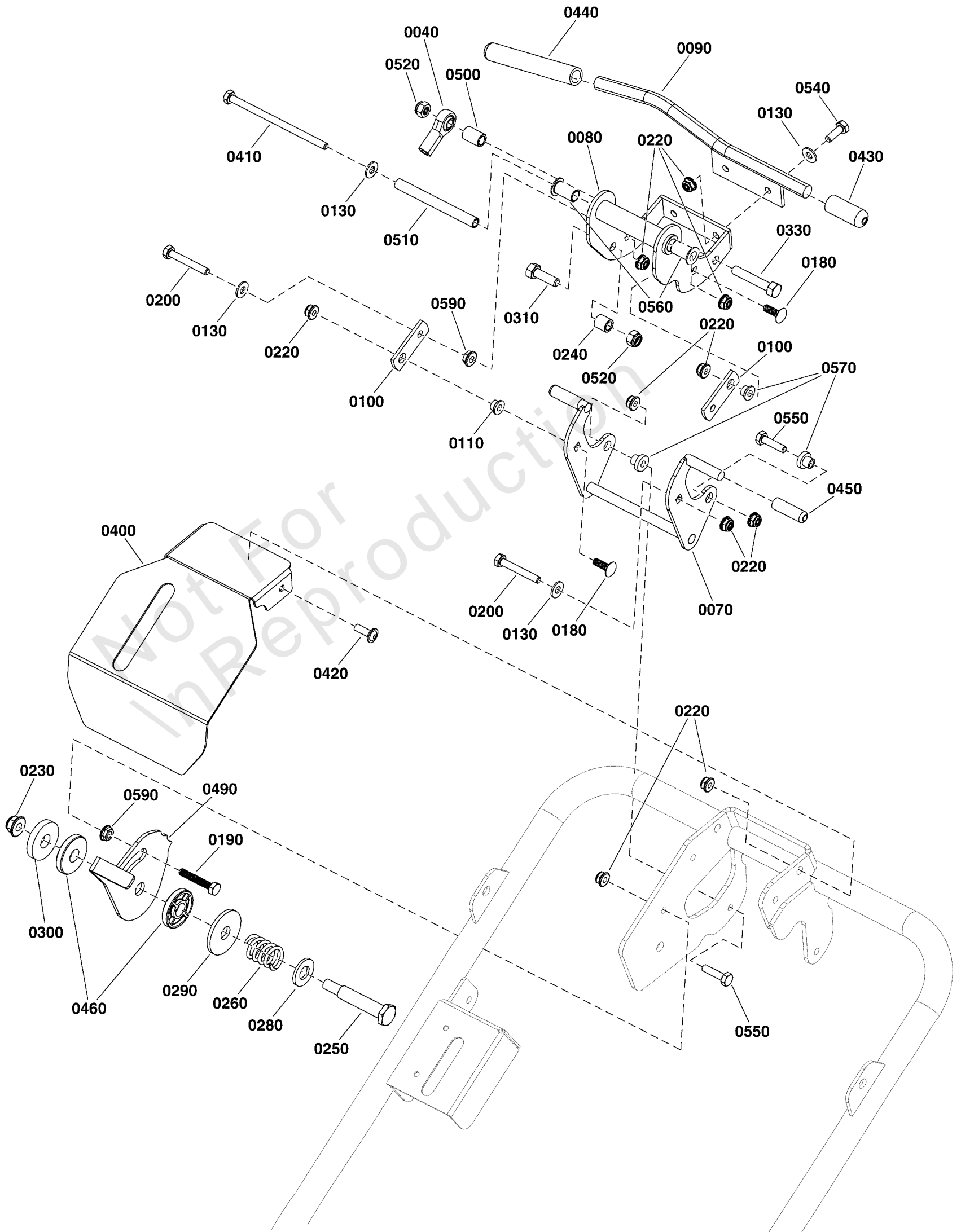

Motion Control Group - Upper

REF NO	PART NO	QTY	DESCRIPTION
0040	5104493	1	BALL JOINT 5/16-24 RH FEMALE BRONZE RACE -(Connects to item #0480 in Motion Control Group - Lower
0070	5418884AA	1	WELD, MOTION CONTROL LINK - BLK
0080	5419033AA	1	WELD, UPPER MOTION CONTROL-BLK
0090	5418877AA	1	WELD, HANDTHUMB CONTROL - BLK
0100	5418815AA	2	PLATE, LINK REVERSE - BLK
0110	5107552	2	SPACER, .251ID X .550OD X .28, CZ
0130	5025154	6	WASHER, 1/4 SAE
0180	80003518	2	BOLT,1/4-20X0.750,GR5,STD NECK,SQ,ZC/CL
0190	5025010X12	1	BOLT, 1/4-20 X 1-1/2 GD5 CZ
0200	5025010X14	2	BOLT, 1/4 X 20 X 1-3/4 GD5 YZ
0220	5025391	8	NUT, 1/4-20 Hex Nylock Flange
0230	5025394	1	NUT, 3/8 - 16 HEX NYLOCK FLANGE
0240	5102148	1	SPACER, .33 X .50 X .50, YZ
0250	2108765	1	BOLT-WHEEL 3/8-16X2.781 .750 THRD YELLOW
0260	5102211	1	SPRING-COMP, .720ID X 1.310LG X .118 WIRE
0280	5025158	1	WASHER, 1/2 SAE
0290	5103282	1	WASHER, .52 X 1.75 X 0.14, CZ
0300	5044913	1	WASHER, .53 X 1.50 X .25
0310	5025011X8	1	BOLT, 5/16-18 X 1" GRD5 YZ
0330	5025011X14	1	BOLT, 5/16-18 X 1-3/4" GD5 YZ
0400	5601185	1	COVER PLATE W/ DECALS, FW15
0410	5025010X36	1	BOLT, 1/4-20 X 4-1/2
0420	5106757	2	SCREW, FLANGE, ALLEN HD, 1/4-20 X .75 SS
0430	5100620	1	GRIP, FOAM, .475 X 1.5 X .095
0440	5021880	1	GRIP, FOAM, .475 X 4.35 X .095
0450	5107721	2	COVER, VINYL, 1.44
0460	5107722	2	SPACER, .52 X 1.50 X .25, PL
0490	5418817AA	1	PLATE, SPEED CONTROL - BLK
0500	5101352	1	SPACER, .33 X .50 X .75
0510	5107536	1	SPACER, .265ID X .375OD X 3.69
0520	5025057	2	NUT, Hex, Nylon Locking, 5/16-18
0540	5025010X6	2	BOLT, 1/4"-20 X 3/4" GD5 YZ
0550	5025010X8	2	BOLT, 1/4-20 X 1" GD5 CZ
0560	5023260	2	BUSHING, FLANGE 3/8ID X 7/8 LONG
0570	5107982	2	SPACER, .25ID X .625OD X .43, CZ
0590	5025126	4	NUT, Hex, Serrated Flange, 1/4-20

Pulleys, Belt, and Idler Arm Group

Note: Unless noted otherwise, use the standard torque specifications

Mfg. No: 5901736

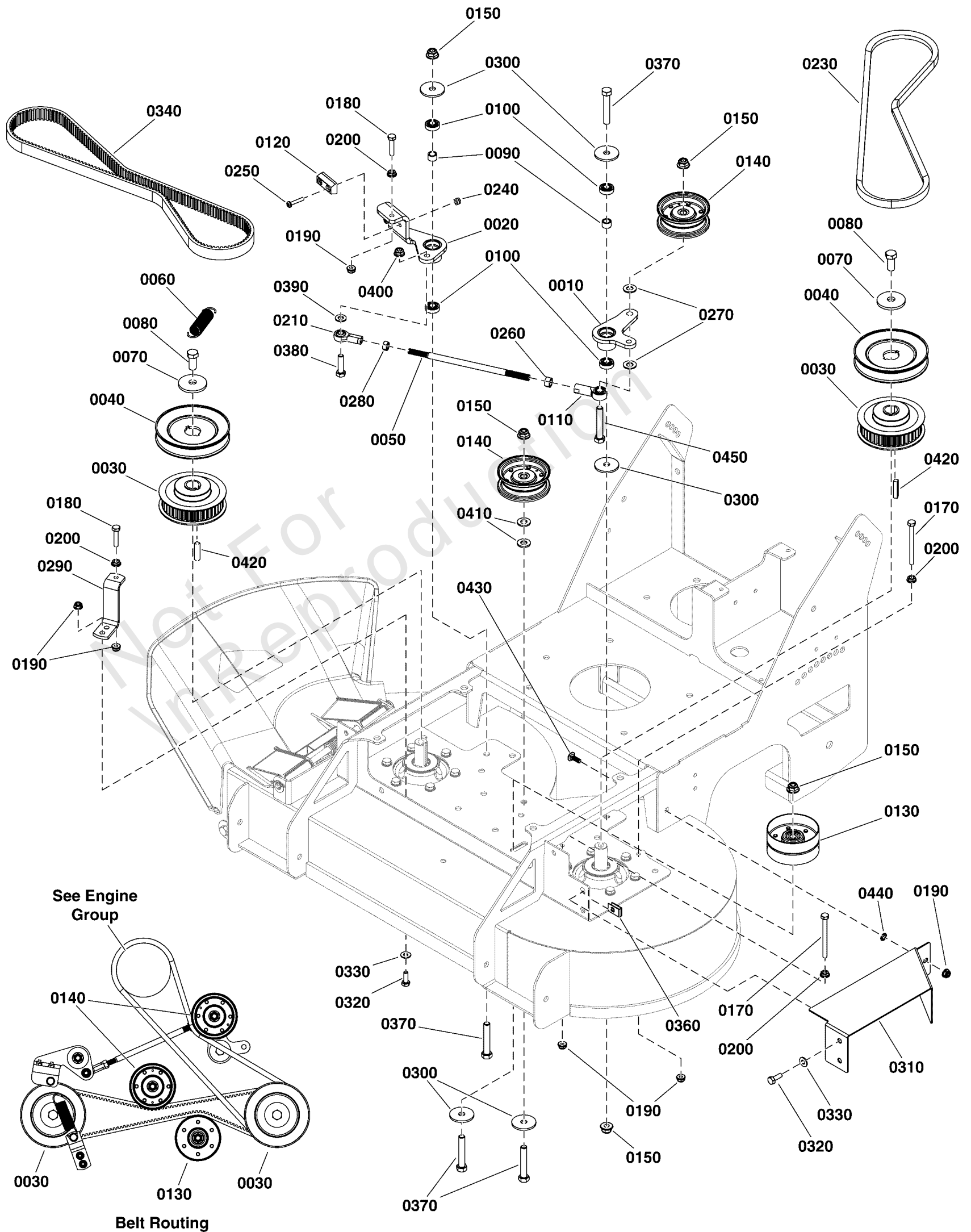

Pulleys, Belt, and Idler Arm Group

REF NO	PART NO	QTY	DESCRIPTION
0010	5417803AA	1	WELD, BLADE ENGAGEMENT ARM - BLK
0020	5417804AA	1	WELD, BRAKE ENGAGEMENT ARM - BLK
0030	5106475	2	PULLEY, TIMED, 20MM, 38 TOOTH
0040	1732951	2	PULLEY, .68" Deep-Groove OD 4.6"
0050	5106429	1	ROD, BRAKE ADJUSTMENT, FW15
0060	5101339	1	SPRING, EXTENSION, 3.281 X .751 X .075 WIRE
0070	1656916	2	WASHER, .475 ID x 1.75 OD x .156 Thick Spring, Black
0080	80020425	2	CAPSCREW-HEX HD 7/16-14X1.000 G5 ZC/CL
0090	5103676	2	SPACER, .39 X .55 X .38, PM, CZ
0100	5102003	4	BEARING, .375" ID X .875" OD X .341" THK
0110	5021683	1	BALL JOINT, 3/8-24 FEMALE
0120	5106441	1	PAD, BRAKE, A SECTION PULLEY
0130	5106481	1	PULLEY, IDLER, FLAT, 3.22" OD X .3/8" ID
0140	5106480	2	PULLEY, IDLER, 2.75"OD X .37"ID, INSERT
0150	5025394	5	NUT, 3/8 - 16 HEX NYLOCK FLANGE
0170	5025010X24	2	BOLT, 1/4-20 X 3 GD5 CZ
0180	5025010X10	2	BOLT, 1/4-20 X 1-1/4 GD5 CZ
0190	5025391	6	NUT, 1/4-20 Hex Nylock Flange
0200	5025126	4	NUT, Hex, Serrated Flange, 1/4-20
0210	5104494	1	BALL JOINT 5/16-24 LH FEMALE BRONZE RACE
0230	5106381	1	BELT, A-SEC, 42.31" EL, ARAMID WRAP
0240	5025271	2	NUT, Hex, Nylon Lock, #10-24
0250	5025270	2	MACHINE SCREW, Truss Head #10-24 x 1
0260	5025035	1	NUT, 3/8-24 HEX (SV)
0270	5025156	2	WASHER, 3/8 SAE
0280	5023212	1	NUT, 5/16-24 HEX, LH
0290	5418455AA	1	MOUNT, DECK SPRING - BLK
0300	5100548	4	WASHER, .390 X 1.50 X .109, YZ
0310	5418450B	1	PLATE, GUARD, LH, FW15 - RED
0320	5025010X6	4	BOLT, 1/4"-20 X 3/4" GD5 YZ
0330	5025154	4	WASHER, 1/4 SAE
0340	5106484	1	BELT, SYNCHRO, 1120-8MPT-20
0360	5022665	2	BODY CLIP, 1/4-20 X 1/2" DEEP
0370	5025013X18	4	BOLT, 3/8-16 X 2-1/4" GD5 CZ
0380	5025055X10	1	BOLT, 5/16-18 x 1-1/4" TFL GD 5
0390	5025155	1	WASHER, 5/16" SAE
0400	5025392	1	NUT, 5/16-18 HEX NYLOCK FLANGE NUT
0410	5025293	2	WASHER, 3/8" GR. 9 FLAT
0420	5050407X10	2	KEY, 1/4" SQ. X 1-1/4
0430	80003518	1	BOLT,1/4-20X0.750,GR5,STD NECK,SQ,ZC/CL
0440	80004801	1	BOLT,1/4,PUSHNUT RETAINER,PHOSPHATE/OIL
0450	5025013X10	1	BOLT, 3/8-16 X 1-1/4" GD5 CZ

Rear Drive Group

Note: Unless noted otherwise, use the standard torque specifications

Mfg. No: 5901736

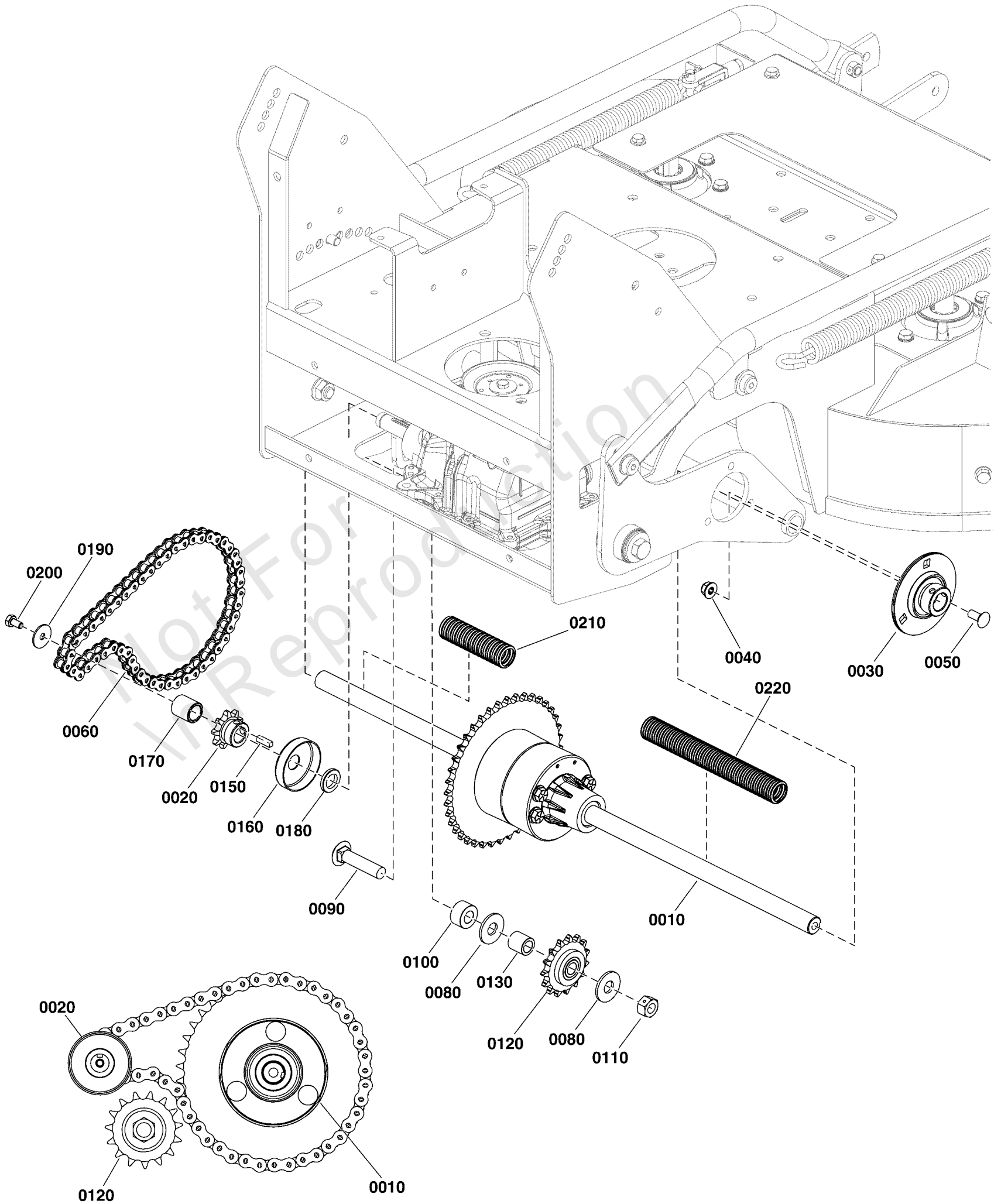

Chain Routing

Rear Drive Group

REF NO	PART NO	QTY	DESCRIPTION
0010	5106304	1	DIFFERENTIAL ASM. FW15
0020	5106406	1	SPROCKET, #40B9, HRD TEETH X .625 BORE
0030	5106319	2	BEARING, 3 BOLT FLG, 3/4 ID, SAPF204-12
0040	-----	6	NUT 5/16-18 HEX FLNG CNTR LCK ZC/CL
0050	5025145X6	6	BOLT, 5/16-18 X 3/4, CARRIAGE, GD5, CZ
0060	5106552	1	CHAIN, #40, O-RING, 51 LINKS
0060-10	5106552X1	1	#40 OFFSET LINK, O-RING TYPE -(Not an illustrated part)
0060-20	5106552X2	1	#40 MASTER LINK, O-RING TYPE -(Not an illustrated part)
0080	5025150	2	WASHER, 1/2" USSZ
0090	5025324X18	1	BOLT, CARRIAGE, 1/2-13 X 2-1/4", GD5 CZ
0100	5101162	1	SPACER, .52 X 1.00 X .56, PM, CZ
0110	5025332	1	NUT, 1/2-13 Hex Side Lock
0120	5107558	1	SPROCKET, ASM, TENSIONER
0130	5107556	1	SPACER, .50 X .75 X .78, CZ
0150	5050403X4	1	KEY, 3/16" SQ. X 3/4
0160	5107882	1	DEBRIS COVER
0170	5107878	1	BUSHING, .64 X .875 X .969
0180	5107879	1	SPACER, .630 X .10 X .155
0190	5025288	1	WASHER, 1/4" Fender
0200	5025457	1	BOLT, 1/4-28 X 1/2, GD5 YZ
0210	5050862X3P5	1	WIRE LOOM, 3/4 ID X 3.5 IN
0220	5050862X7P5		WIRE LOOM, 3/4 ID X 7.5 IN

Spindle Service Parts - 5417770

Note: Unless noted otherwise, use the standard torque specifications

Mfg. No: 5901736

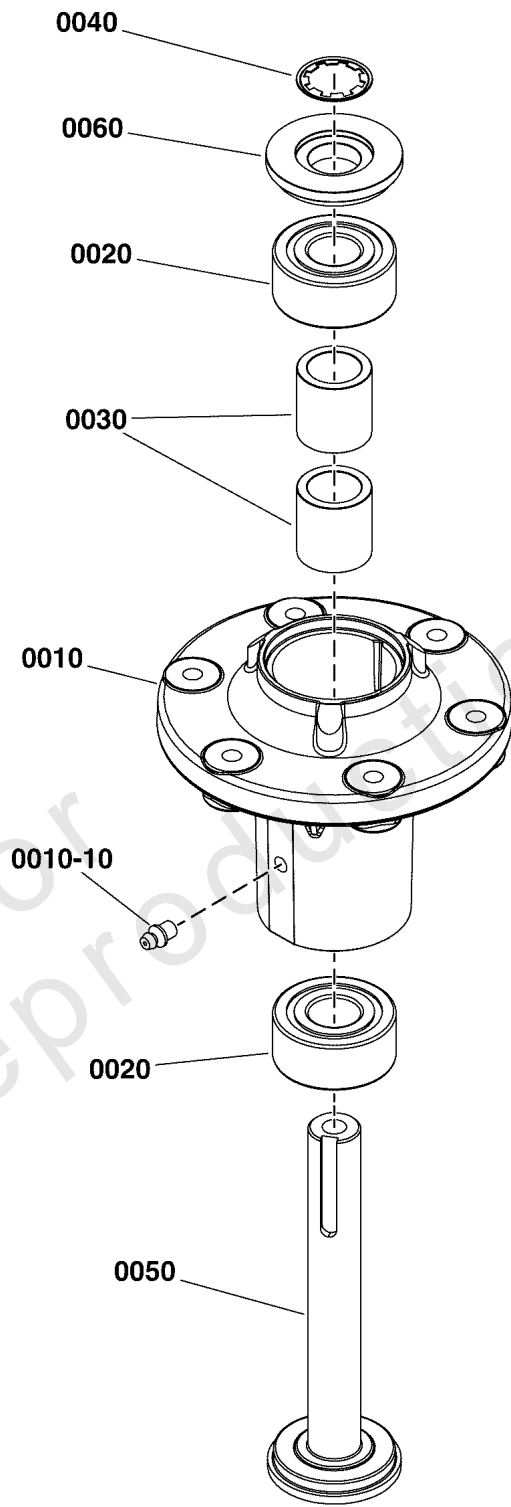

Spindle Service Parts - 5417770

REF NO	PART NO	QTY	DESCRIPTION
0010	1761445	1	HOUSING, SPINDLE - CAST ALUM W/ ZERK
0010-10	1704314	1	LUBE FITTING, 1/4 Drive , Check Ball
0020	5105576	2	BEARING 5204-2RS, DOUBLE ROW
0030	5105533	2	SPACER, .81 X 1.13 X 1.18, PM
0040	1960766	1	RING, Self-Locking, 46" Mower
0050	5106416	1	SHAFT, MOWER SPINDLE, KEYED
0060	1735323	1	SHIELD-ARBOR, 2.050OD 46" MWR

Not For In Reproduction

Transaxle SERVICE Parts - Hydro-Gear RT-310 (5105873)

Note: Unless noted otherwise, use the standard torque specifications

Mfg. No: 5901736

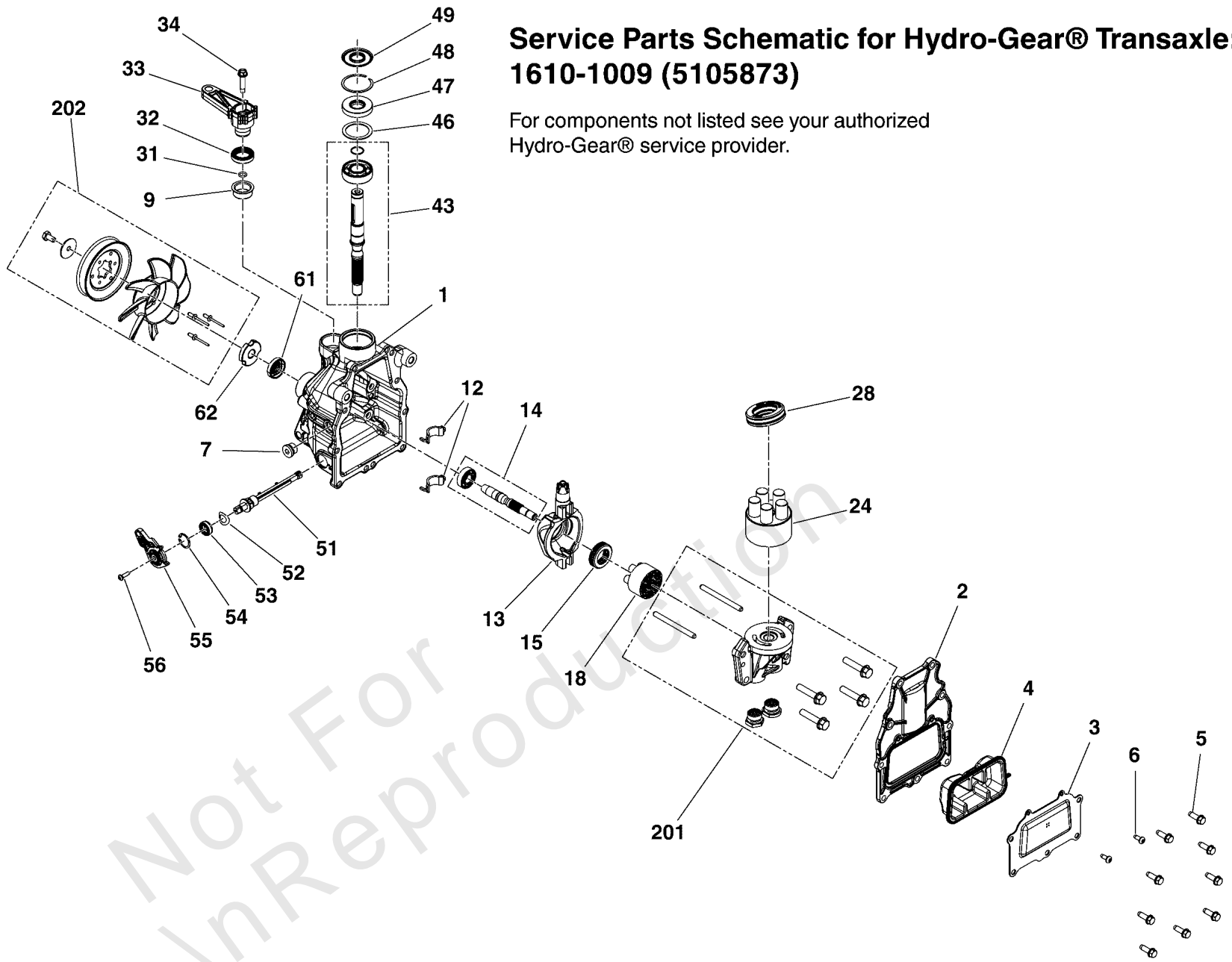

Transaxle SERVICE Parts - Hydro-Gear RT-310 (5105873)

REF NO	PART NO	QTY	DESCRIPTION
1	-----	1	HOUSING, MAIN
2	-----	1	COVER
3	-----	1	PLATE, EXPANSION
4	-----	1	BLADDER
5	-----	9	SCREW, HEX WASHER 1/4-20 X .75
6	-----	2	BOLT, SELF-TAPPING
7	-----	1	PLUG, 9/16-18 STR THREAD SOCKET HEAD
9	-----	1	GUIDE, PLASTIC ALIGNMENT
12	-----	2	BEARING, CRADLE
13	-----	1	SWASH_PLATE
14	-----	1	KIT, INPUT SHAFT
15	-----	1	BEARING, THRUST 21 X 35 X 10
18	-----	1	KIT, 3cc BLOCK
24	-----	1	KIT, BLOCK 10cc CYLINDER
28	-----	1	BEARING, THRUST 30 x 52 x 13
31	-----	1	O-RING, -011, .301 X .07, 70A
32	-----	1	SEAL, LIP 20 X 30 X 7
33	-----	1	ARM, CONTROL
34	-----	1	SCREW, HEX WASHER
43	-----	1	KIT, MOTOR SHAFT
46	1730272	1	SPACER (50951)
47	5100161X3	1	OUTPUT SHAFT SEAL, 17X40X7, HR #51161
48	-----	1	RING, M40, RET, INT
49	-----	1	SLEEVE, SEAL GUARD
51	-----	1	ACTUATOR, BYPASS
52	-----	1	WASHER, .45 X .73 X .01, SPRING
53	5104471X1	1	SEAL, .375 X .750 X .25 LIP, H/G 51626
54	-----	1	BYPASS RETAINING RING 2
55	-----	1	ARM, BYPASS
56	-----	1	SCREW, M4 X 16, WUPLAST
61	-----	1	SEAL, .47 X 1.10 X .28, LIP, TC4
62	-----	1	HUB, PULLEY DIA. 141
200	-----	1	KIT, SEAL
201	-----	1	KIT, CENTER SECTION
202	-----	1	KIT, FAN/PULLEY

Wheel and Tire Group

Note: Unless noted otherwise, use the standard torque specifications

Mfg. No: 5901736

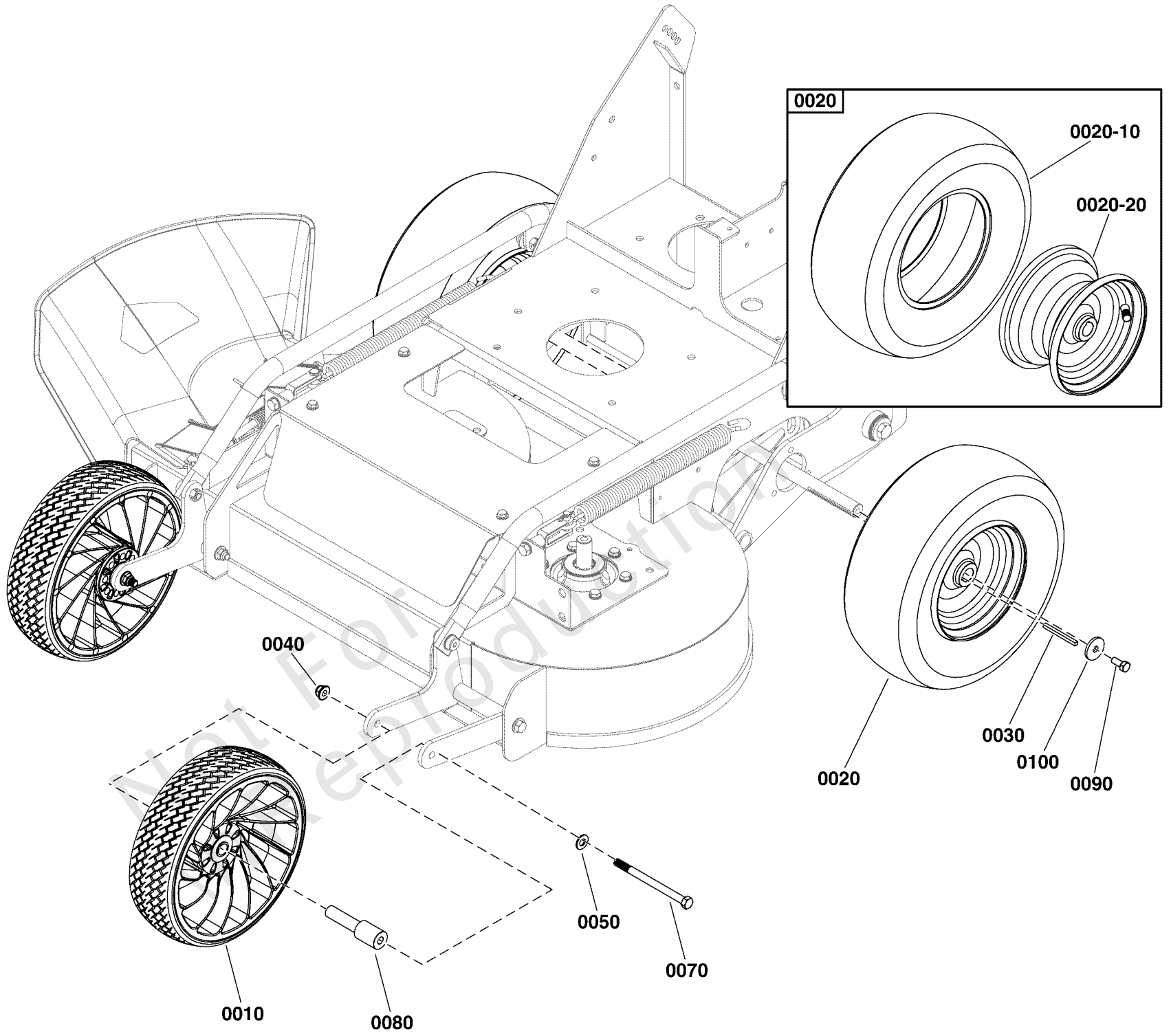

Wheel and Tire Group

REF NO	PART NO	QTY	DESCRIPTION
0010	5106322	2	TIRE/WHEEL, FRONT, FW15
0020	5106328	2	TIRE/WHEEL, REAR, FW15 - BLACK
0020-10	5106328X1	2	TIRE, 13X5.00-6 4 PLY TL TURF -(One per tire.)
0020-20	5106328X2	2	WHEEL ASSEMBLY, 6" X 3-1/4" BEAD WIDTH -(One per tire.)
0030	5048409	2	KEY, 3/16 SQ. X 2-1/2
0040	5025394	2	NUT, 3/8 - 16 HEX NYLOCK FLANGE
0050	5025156	2	WASHER, 3/8 SAE
0070	5025013X40	2	BOLT, 3/8-16 X 5" GD5
0080	5106512	2	SPACER, SHOULDER, .390 X 3.69, CZ
0090	5025011X6	2	BOLT, 5/16-18 X 3/4 GD5
0100	5044617	2	WASHER, .34 X 1.25 X 10 GA

Not For In Reproduction

Hardware Identification & Torque Specifications

Torque Specification Chart								
FOR STANDARD METRIC MACHINE HARDWARE (Tolerance ± 20%)								
Property Class	5.6		8.8		10.9		12.9	
	Class 5.6		Class 8.8		Class 10.9		Class 12.9	
Size Of Hardware	in/lbs	Nm.	in/lbs	Nm.	in/lbs	Nm.	in/lbs	Nm.
	ft/lbs		ft/lbs		ft/lbs		ft/lbs	
M3	5.88	.56	13.44	1.28	19.2	1.80	22.92	2.15
M4	13.44	1.28	30.72	2.90	43.44	4.10	52.56	4.95
M5	26.4	2.50	60.96	5.75	5.97	8.10	7.15	9.7
M6	44.64	4.3	7.3	9.9	10.3	14	12.1	16.5
M7	5.2	7.1	12.1	16.5	16.9	23	19.9	27
M8	7.7	10.5	17.7	24	25	34	29	40
M10	15	21	35	48	50	67	59	81
M12	26	36	61	83	86.2	117	103	140
M14	42	58	101	132	136	185	162	220
M16	64	88	147	200	210	285	250	340
M18	89	121	202	275	287	390	346	470
M20	126	171	290	390	405	550	486	660
M22	169	230	390	530	559	745	656	890
M24	217	295	497	375	708	960	840	1140
M27	320	435	733	995	1032	1400	1239	1680
M30	435	590	995	1350	1401	1900	1681	2280
M33	590	800	1349	1830	1902	2580	2278	3090
M36	759	1030	1740	2360	2441	3310	2935	3980
M39	988	1340	2249	3050	3163	4290	3798	5150

Torque Specification Chart						
FOR STANDARD MACHINE HARDWARE (Tolerance ± 20%)						
Hardware Grade	No Marks		SAE Grade 5		SAE Grade 8	
	SAE Grade 2		SAE Grade 5		SAE Grade 8	
Size Of Hardware	in/lbs	Nm.	in/lbs	Nm.	in/lbs	Nm.
	ft/lbs		ft/lbs		ft/lbs	
8-32	19	2.1	30	3.4	41	4.6
8-36	20	2.3	31	3.5	43	4.9
10-24	27	3.1	43	4.9	60	6.8
10-32	31	3.5	49	5.5	68	7.7
1/4-20	66	7.6	8	10.9	12	16.3
1/4-28	76	8.6	10	13.6	14	19.0
5/16-18	11	15.0	17	23.1	25	34.0
5/16-24	12	16.3	19	25.8	29	34.0
3/8-16	20	27.2	30	40.8	45	61.2
3/8-24	23	31.3	35	47.6	50	68.0
7/16-14	30	40.8	50	68.0	70	95.2
7/16-20	35	47.6	55	74.8	80	108.8
1/2-13	50	68.0	75	102.0	110	149.6
1/2-20	55	74.8	90	122.4	120	163.2
9/16-12	65	88.4	110	149.6	150	204.0
9/16-18	75	102.0	120	163.2	170	231.2
5/8-11	90	122.4	150	204.0	220	299.2
5/8-18	100	136	180	244.8	240	326.4
3/4-10	160	217.6	260	353.6	386	525.0
3/4-16	180	244.8	300	408.0	420	571.2
7/8-9	140	190.4	400	544.0	600	816.0
7/8-14	155	210.8	440	598.4	660	897.6
1-8	220	299.2	580	788.8	900	1,244.0
1-12	240	326.4	640	870.4	1,000	1,360.0

The guides and ruler furnished below are designed to help you select the appropriate hardware.



Nut, M8

Thread Diameter (mm)

Inside Diameter (in) Threads per inch

Nut, 1/2-16



Screw, M8- 1.25 x 25

Thread Diameter (mm) Distance between threads (mm) Body Length (mm)

Body Diameter Threads per inch Body Length (in)

Screw, 1/2- 16 x 2



Standard Hardware Sizing

When a washer or nut is identified as 1/2" (M8), this is the *Nominal size*, meaning the *inside diameter* is 1/2 inch (8mm metric thread diameter); if a second number is present it represents the *threads per inch* (distance between threads).

When bolt or capscrew is identified as 1/2 - 16 x 2" (M8 - 1.25 x 50), this means the *Nominal size*, or body diameter is 1/2 inch (8mm metric thread diameter), the second number, 16, represents the *threads per inch*, (*distance between threads*). The final number is the body length of the bolt or screw, 2 inches (50mm).

NOTES

- These torque values are to be used for all hardware excluding: locknuts, self-tapping screws, thread forming screws, sheet metal screws and socket head setscrews.
- Recommended seating torque values for locknuts:
 - for prevailing torque locknuts - use 65% of grade 5 torques.
 - for flange whizlock nuts and screws - use 135% of grade 5 torques.
- Unless otherwise noted on assembly drawings, all torque values must meet this specification.

Common Hardware Types

Hex Head Capscrew



Washer



Carriage Bolt



Hex Nut

Wrench & Fastener Size Guide

1/4" Bolt or Nut Wrench—7/16"	5/16" Bolt or Nut Wrench—1/2"	3/8" Bolt or Nut Wrench—9/16"	7/16" Bolt or Nut Wrench (Bolt)—5/8" Wrench (Nut)—11/16"	1/2" Bolt or Nut Wrench—3/4"
M6 Bolt or Nut Wrench—10mm	M8 Bolt or Nut Wrench—13mm	M10 Bolt or Nut Wrench—17mm	M12 Bolt or Nut Wrench—19mm	M14 Bolt or Nut Wrench—22mm

